

Utilizing Energy Storage to Improve Distribution Reliability



Arindam Maitra, Jouni Peppanen, Gaurav Singh, EPRI

2018 PV Systems Symposium
Hotel Albuquerque at Old Town
May 3rd, 2018

Background

- Traditional distribution system reliability improvement techniques classified as:
 - A. Grid hardening
 - B. Adding system intelligence
- Microgrids and energy storage have emerged as an alternative in the past few years
- Lack of understanding about how and when system intelligence and microgrids are to be applied
- Lack of common framework that helps utilities apply these reliability methods in a scientific and economically justifiable way
- Lack of understanding as to how Microgrids can be located, sized and operated for a distribution reliability improvement objective

Objective

- Apply reliability improvement techniques on an actual utility distribution feeder with poor reliability numbers
- Demonstrate effectiveness of distribution automation and Distributed Energy Resources (DERs) in meeting reliability objective
- Contrast reliability techniques by calculating cost per unit reliability improvement
- Develop a scientific method to locate, size and operate microgrids using utility reliability targets as a benchmark
- Collate all reliability methods into a common framework that utilities can use effectively (and easily) to meet their reliability objective

Proposed Framework

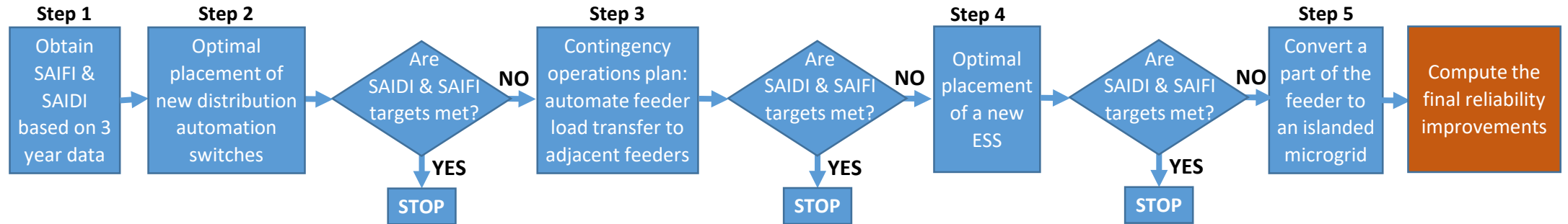

- **Step 1 – Data Gathering:** Gather historical fault data to calculate feeder baseline SAIDI and SAIFI and component failure rates (FR).
- **Step 2 – Optimal Switch Placement:** Use a switch placement algorithm to optimally place distribution automation (DA) switches to minimize customer interruptions.
- **Step 3 – Load Transfer schemes:** Explore option of load transfer using neighboring feeders.
- **Step 4 – Optimal ESS Placement:** Identify section(s) of the feeder to be restored using storage enabled microgrids based upon reliability objective.
- **Step 5 – Microgrid Analysis:** Compute size of the energy storage system (ESS) based upon the load size of the feeder section to be restored.

Demonstration case study: Feeder Overview

- Distribution feeder at 44 kV voltage level
- Total length = 60 km
- Total customers ~ 10,000
- Peak Load ~25 MW
- Feeder has substation breaker, two tie points to neighboring feeders and a protective switch on a lateral (near “DS5” on the diagram)
- Grid hardening using vegetation trimming not possible on feeder due to customer preferences

Feeder Single Line Diagram

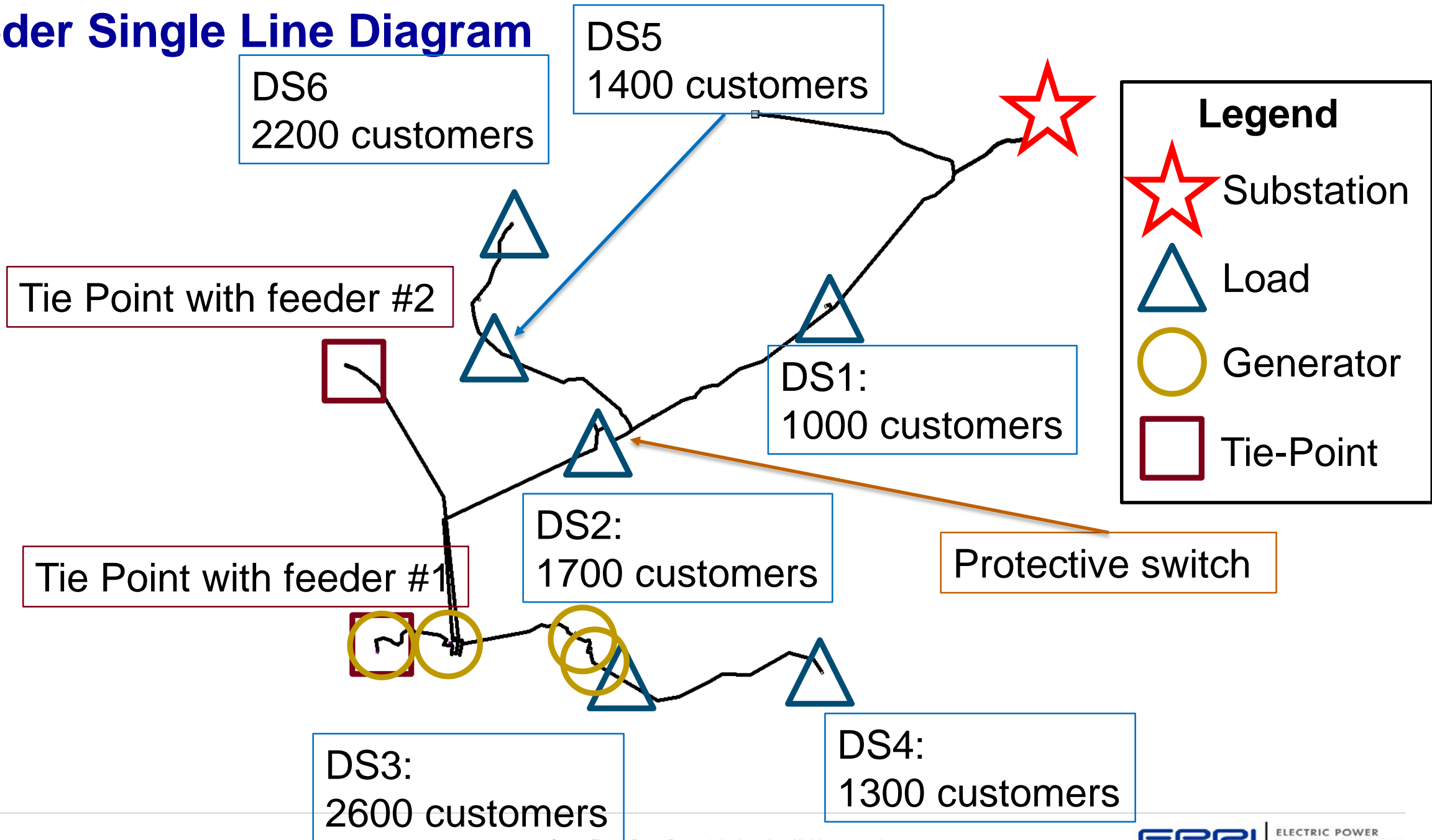

Application of Framework: Step 1

- Due to dense vegetation, 70% faults occur within first 30% of feeder length.
- Three years' worth of fault data used to calculate feeder baseline SAIFI and SAIDI (upon which improvement is sought).
- Feeder SAIFI = 3.34 interruptions/customer.
- Feeder SAIDI = 17.6 hrs/customer.
- CAIDI = 5.3 hrs/interruption (used as 'average repair time' in reliability analysis).
- Utility reliability targets: SAIFI = 2 interruptions/customer and SAIDI = 5.5 hrs/customer.

Step 1 (contd.)

- Failure rate assigned to each line section of the feeder:

$$\lambda = \frac{\textit{Total faults on line section}}{\textit{Total length of line section}} * (\% \textit{ perm. faults}),$$

Where ‘% perm. Faults’ indicates percentage of line section faults that were permanent.





Step 2: Optimal Switch Placement

Switches on Feeder: 1
SAIFI : 3.34
SAIDI : 17.6

Switches on Feeder: 2
SAIFI : 3.09
SAIDI : 16.3

Switches on Feeder: 3
SAIFI : 3.07
SAIDI : 16.2

Legend

-  Load
-  Switch
-  Substation
-  ESS
-  Breaker
- FR Failure Rate

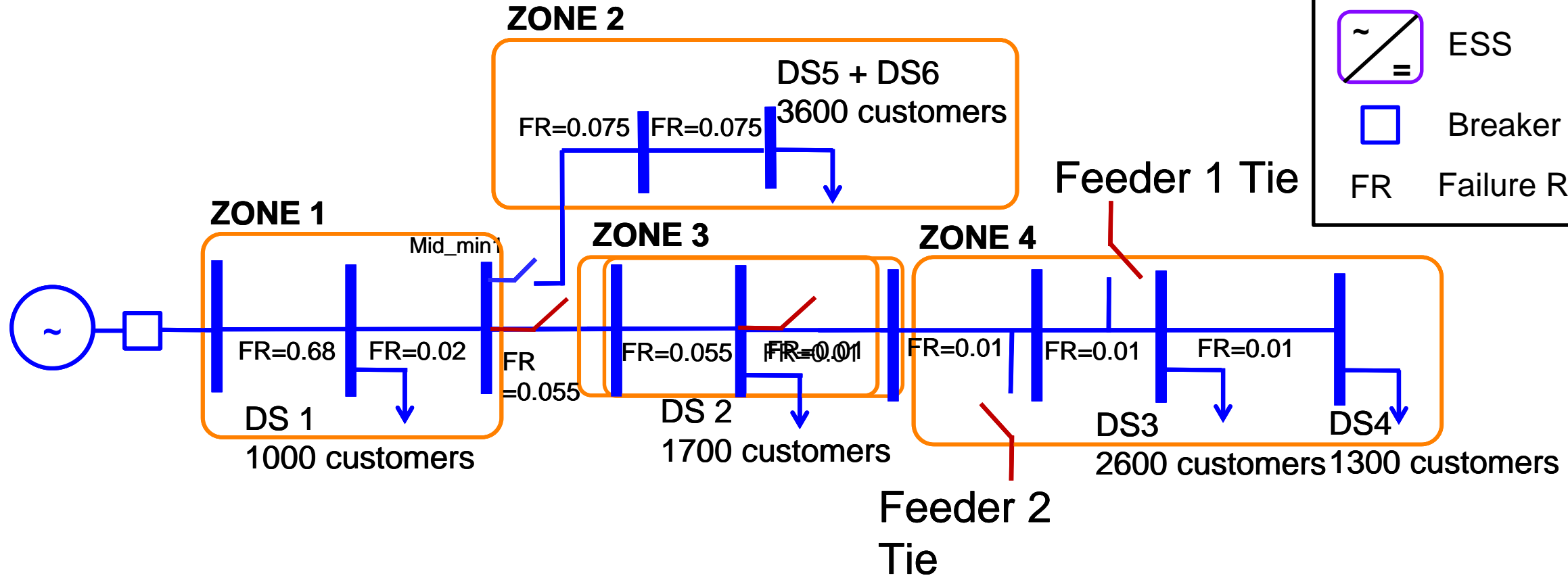

Step 3 : Load Transfer

- 2 additional switches effectively bifurcate feeder into 4 zones.
- Currently no provision to operate zones independently.
- Load transfer switches currently not automated.
- Load transfer option explored as benefits from DA switch placement become marginal.
- Load transfer more expensive (changes to protection coordination, additional infrastructure costs etc) but capable of energizing all of zone 4 (and hence, large improvement in reliability).

Step 3: Load transfer

Switches on Feeder: 3
 SAIFI : 3.07
 SAIDI : 16.2

Switches on Feeder: 3 + Load Transfer
 SAIFI : 1.9
 SAIDI : 10.03

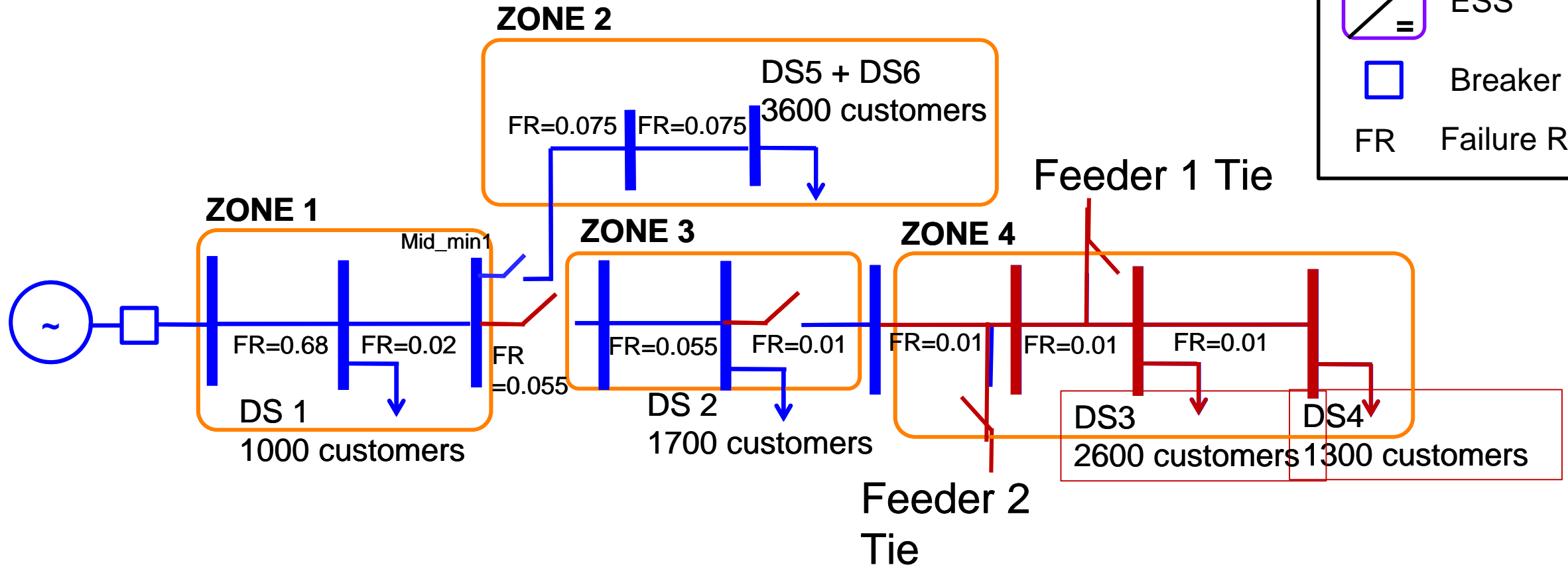
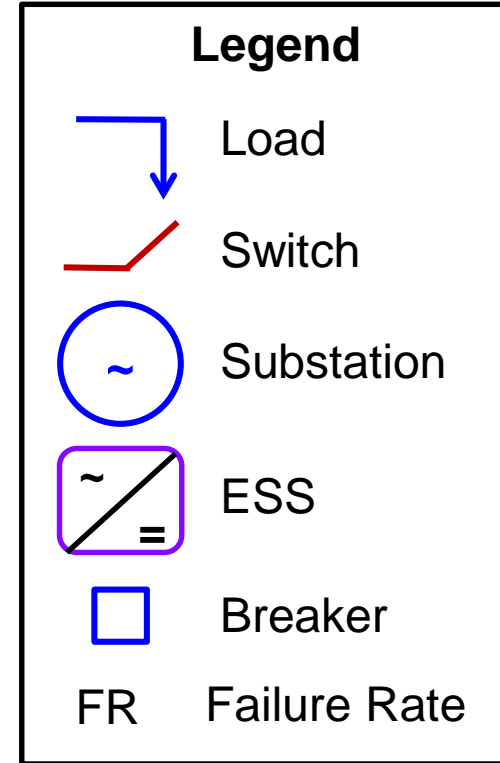

Step 4: ESS Placement

- SAIFI target met during Step 3. SAIDI still unacceptably high.
- Zone 1 connected to substation. However, zones 2 and 3 can be restored using energy storage systems (ESS).
- SAIFI and SAIDI improvements achieved by operating zone 2 / zone 3 as microgrid in islanded mode were calculated. Operating zone 2 as an islanded microgrid was found to meet reliability objective.

BESS Location	SAIFI	SAIDI
Zone 3	1.48	7.81
Zone 2	0.98	5.22
Zone 2 and Zone 3	0.56	2.98

Step 5 : Sizing the battery for Microgrid operation

- System average load determined from load duration curve (see figure).
- Load in Zone 2 calculated from spot load data and system average load.
- Battery support duration set equal to average repair time (5.3 hrs).
- Size of battery needed calculated to be 34.5 (28.5) MWh for Zone 2 (Zone 3).

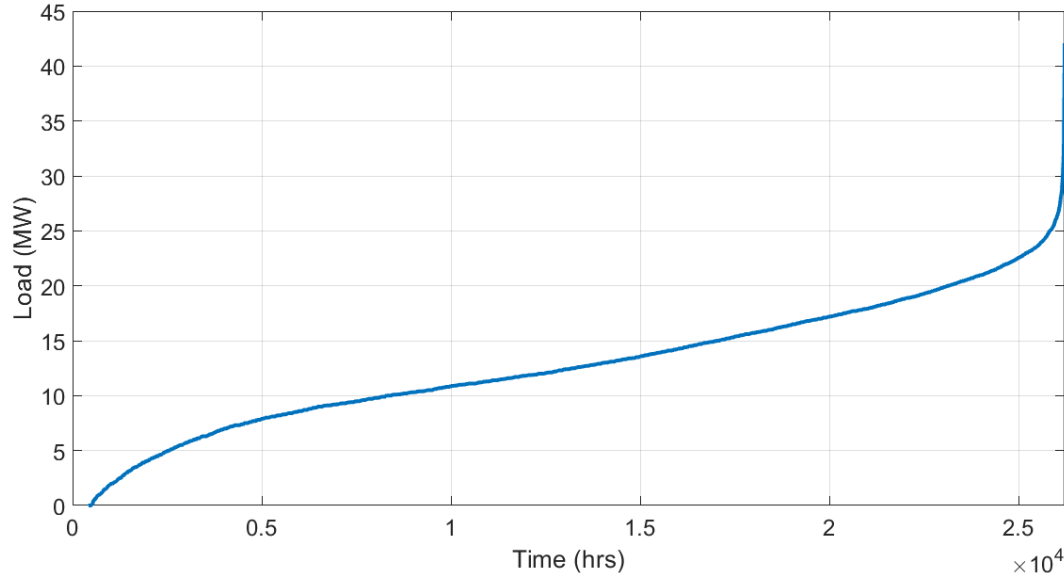

Figure: System Load data over 3 years. Load remains below 25 MW ~90% of the time.

Cost Analysis

- Cost of distribution automation switch ~ \$100k per switch.
- Installed cost of battery storage assumed to be ~\$500/kWh.
- Cost of load transfer assumed to be equal to cost of DA switch for analysis. Infrastructure changes not considered/specified.
- Benefits calculated as 'dollar amount' per unit SAIFI/SAIDI improvement.
- Results presented as a unified solution to the utility to decide order of priority of implementation based upon capital available/reliability improvement sought.

Cost-Benefit Analysis outcomes

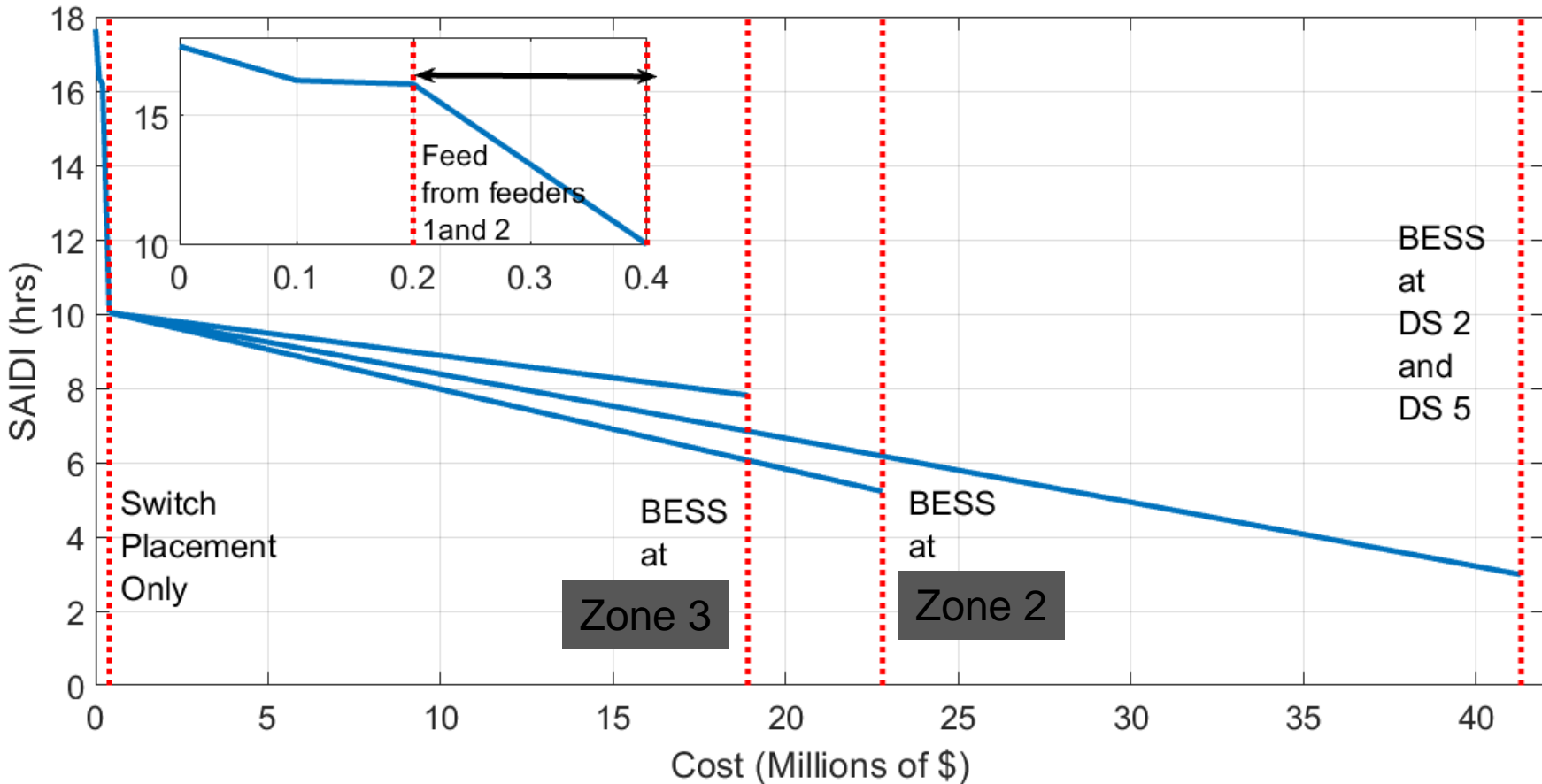

Figure: Benefits from the reliability improvement study plotted as a function of cost. Inset: benefits from switch placement alone.

Conclusions

- Due to feeder topology, recloser placement alone yields marginal benefits.
- Maximum benefits derived from fault isolation **AND** partial feeder restoration.
- Restoring parts of the feeder that do not have access to generation sources, yields high benefits.
- High cost of Battery Storage leads to prohibitively high Microgrid costs.
- Load needs to be separated as ‘high priority’ or ‘low priority’ to bring down the size of the Storage system and hence, cost.



Together...Shaping the Future of Electricity